

# PAR 1 RGBW

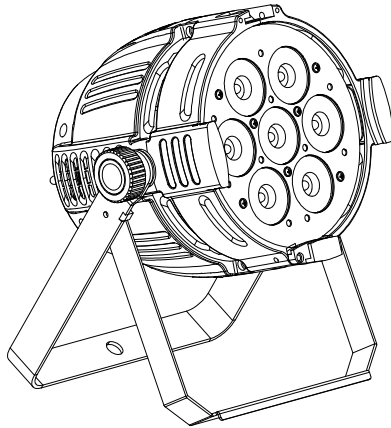

## User Manual



© 2013-2015 Martin Professional ApS. Information subject to change without notice. Martin Professional and all affiliated companies disclaim liability for any injury, damage, direct or indirect loss, consequential or economic loss or any other loss occasioned by the use of, inability to use or reliance on the information contained in this manual. The Martin logo, the RUSH by Martin logo, the RUSH by Martin name, the Martin name and all other trademarks in this document pertaining to services or products by Martin Professional or its affiliates and subsidiaries are trademarks owned or licensed by Martin Professional or its affiliates or subsidiaries.

Martin Professional • Olof Palmes Allé 18 • 8200 Aarhus N • Denmark • [www.martin.com](http://www.martin.com)

Manual: Revision E

# Table of contents

Safety information .....	5
Introduction .....	10
Before using the product .....	10
Physical installation.....	11
Fastening the fixture to a flat surface .....	11
Mounting the fixture on a truss .....	11
Securing with a safety cable.....	12
AC power .....	13
Linking fixtures to power in a chain .....	14
Fixture overview .....	15
Control data link.....	17
Tips for reliable data transmission .....	17
Connecting the DMX data link.....	18
Fixture setup .....	18
Using the control menus.....	18
DMX addressing .....	18
DMX channel modes .....	19
Show mode.....	19
Dimmer modes .....	20
Sound activation (music trig).....	21
Microphone sensitivity .....	21
DMX state.....	21
LED display on/off .....	22
LED display inversion.....	22
White balance adjustment.....	22
Manual mode.....	23
Auto test .....	23
Temperature readout.....	24
Fixture operating hours readout .....	24
Firmware version .....	24
Effects .....	25
Color control .....	25
Electronic dimming .....	25
Shutter/Strobe .....	25

Maintenance .....	26
Cleaning .....	26
Replacing the primary fuse.....	27
Service and repairs .....	27
DMX protocols .....	28
4-channel mode.....	28
5-channel mode.....	28
7-channel mode.....	28
Control menus.....	30
Troubleshooting .....	33
Specifications .....	35

# Safety information



## WARNING!

**Read the safety precautions in this manual before installing, operating or servicing this product.**

The following symbols are used to identify important safety information on the product and in this manual:



**Warning!**

**Safety hazard.  
Risk of severe  
injury or  
death.**



**Warning!**

**Powerful light  
emission. Risk  
of eye injury.**



**Warning!**

**See user  
manual for  
important  
safety  
information.**



**Warning!**

**Hazardous  
voltage. Risk  
of lethal or  
severe electric  
shock.**



**Warning!**

**Hot surfaces  
and fire  
hazard.**



Warning! Risk Group 1 product according to EN 62471. Do not stare directly into the beam. Do not view the light output with optical instruments or any device that may concentrate the beam.

This lighting fixture is for professional use only and must be installed by a qualified technician. It is not for household use. It presents risks of severe injury or death due to fire hazards, electric shock and falls. It produces a powerful, concentrated beam of light that can create a fire hazard or a risk of eye injury if the safety precautions below are not followed.



Install, operate and service RUSH by Martin™ products only as directed in their user manuals, or you may create a safety hazard or cause damage that is not covered by product warranties.

Follow the safety precautions listed below and observe all warnings in this manual and printed on the product. Keep this user manual for future use.

For the latest user documentation and other information for this and all Martin™ products, please visit the Martin website at <http://www.martin.com>

If you have any questions about how to install, operate or service the fixture safely, please contact your Martin™ distributor (see [www.martin.com/distributors](http://www.martin.com/distributors) for details) or call the Martin™ 24-hour service hotline on +45 8740 0000, or in the USA on 1-888-tech-180.

Respect all locally applicable laws, codes and regulations when installing, operating or servicing the fixture.



### **Protection from electric shock**

Do not expose the fixture to rain or moisture.

Disconnect the fixture from AC power before carrying out any installation or maintenance work and when the fixture is not in use.

Ensure that the fixture is electrically connected to ground (earth).

Use only a source of AC mains power that complies with local building and electrical codes and has both overload and ground-fault (earth-fault) protection.

Socket outlets or external power switches used to supply the fixture with power must be located near the fixture and easily accessible so that the fixture can easily be disconnected from power.

Replace defective fuses with ones of the specified type and rating only.

Disconnect the fixture from power immediately if the power plug or any seal, cover, cable, or other component is damaged, defective, deformed, wet or showing signs of overheating. Do not reapply power until repairs have been completed

Before using the fixture, check that all power distribution equipment and cables are in perfect condition and rated for the electrical requirements of all connected devices.

Use only Neutrik PowerCon cable connectors to connect to power sockets.

Do not connect devices to power in a chain that will exceed the electrical ratings of any cable or connector used in the chain.

The supplied power input cable is rated 6 A and can safely supply only one fixture with mains power. Do not connect any device to the fixture's MAINS OUT connector when using this cable. If you replace this cable and also use the replacement cable to supply only one fixture with mains power, the replacement cable must also be rated 6 A minimum, have three conductors 18 AWG or 0.75 mm<sup>2</sup> minimum conductor size, have an outer cable diameter of 6 - 15 mm (0.2 - 0.6 in.) and be temperature-rated to suit the application. In the USA and Canada the cable must be UL listed, type SJT or equivalent. In the EU the cable must be type H05VV-F or equivalent.

To connect fixtures to mains power in a chain, you must first obtain 14 AWG or 1.5 mm<sup>2</sup> power input and throughput cables that are 16 A rated and temperature-rated to suit the application. In the USA and Canada the cables must be UL-listed, type SJT or equivalent. In the EU the cables must be type H05VV-F or equivalent. Suitable cables with Neutrik PowerCon connectors are available from Martin™ (see 'Accessories' on page 37). If you use these cables, you can connect fixtures to power in a linked chain, MAINS OUT throughput socket to MAINS IN input socket, but do not link more than:

- eight (8) RUSH PAR 1 fixtures in total at 100-120 V, or
- sixteen (16) RUSH PAR 1 fixtures in total at 200-240 V.

The voltage and frequency at the MAINS OUT socket are the same as the voltage and frequency applied to the MAINS IN socket. Only connect devices to the MAINS OUT socket that accept this voltage and frequency.



### **Protection from burns and fire**

Do not operate the fixture if the ambient temperature ( $T_a$ ) exceeds 40° C (104° F).

The surface of the product casing can reach up to 85° C (185° F) during operation. Avoid contact by persons and materials. Allow the fixture to cool for at least 10 minutes before handling.

Keep flammable materials well away from the fixture. Keep all combustible materials (e.g. fabric, wood, paper) at least 100 mm (4 in.) away from the fixture head.

Ensure that there is free and unobstructed airflow around the fixture. Provide a minimum clearance of 100 mm (4 in.) around fans and air vents.

Do not illuminate surfaces within 200 mm (7.9 ins.) of the fixture.

Do not attempt to bypass thermostatic switches or fuses.

Connect only other fixtures of the same type to the power throughput sockets. Do not connect any other type of device to these sockets.

Do not stick filters, masks or other materials onto any optical component.



### **Protection from eye injury**

Do not stare directly into the product's light output.

Do not look at the light output with magnifiers, telescopes, binoculars or similar optical instruments that may concentrate the light output.

Ensure that persons are not looking directly into the LEDs when the product lights up suddenly. This can happen when power is applied, when the product receives a DMX signal, or when certain control menu items are selected.

To minimize the risk of eye irritation or injury, disconnect the fixture from power at all times when the fixture is not in use, and provide well-lit conditions to reduce the pupil diameter of anyone working on or near the fixture.



### **Protection from injury**

Fasten the fixture securely to a fixed surface or structure when in use. The fixture is not portable when installed.

Ensure that any supporting structure and/or hardware used can hold at least 10 times the weight of all the devices they support.

If suspending from a rigging structure, fasten the fixture to a rigging clamp. Do not use safety cables as the primary means of support.



If the fixture is installed in a location where it may cause injury or damage if it falls, install as directed in this manual a secondary attachment such as a safety cable that will hold the fixture if a primary attachment fails. The secondary attachment must be approved by an official body such as TÜV as a safety attachment for the weight that it secures, must comply with EN 60598-2-17 Section 17.6.6 and must be capable of bearing a static suspended load that is ten times the weight of the fixture and all installed accessories.

Check that all external covers and rigging hardware are securely fastened.

Block access below the work area and work from a stable platform whenever installing, servicing or moving the fixture.

Do not operate the fixture with missing or damaged covers, shields or any optical component.

In the event of an operating problem, stop using the fixture immediately and disconnect it from power. Do not attempt to use a fixture that is obviously damaged.

Do not modify the fixture in any way not described in this manual or install other than genuine RUSH by Martin™ parts.

Refer any service operation not described in this manual to a qualified technician.

# Introduction

The PAR 1 RGBW is a powerful LED lamp incorporating seven 10 W RGBW long-life CREE LEDs. It provides RGBW color mixing, 32 color presets, smooth electronic dimming, as well as strobe effects. The device is extremely rugged, lightweight and compact, and is ideal for mobile DJ's or small fixed installations.

The fixture can be controlled using any DMX-compliant controller, and it has three DMX control modes providing basic or more complex control capability. It can also function as a standalone device, running pre-programmed shows in show mode, with the option of sound-activated scene triggering.

The fixture is supplied with this user manual, a 1.5 m (5 ft.) power cable (local power plug not included) and a folding bracket that can also be used for rigging clamp attachment.

## Before using the product

1. Read 'Safety information' on page 5 before installing, operating or servicing the fixture.
2. Unpack and ensure that there is no transportation damage before using the fixture. Do not attempt to operate a damaged fixture.
3. If the fixture is not going to be hard-wired to a mains supply, install as directed in this manual a local power plug (not supplied) on the supplied power cable.
4. Before operating, ensure that the voltage and frequency of the power supply match the power requirements of the fixture.
5. Check the RUSH support pages on the Martin Professional website at [www.martin.com](http://www.martin.com) for the most recent user documentation and technical information about the fixture. RUSH by Martin™ user manual revisions are identified by the revision letter at the bottom of the inside cover.

Note that when the fixture is powered on for the first time, it may smoke slightly as it warms up, but this will only last a few minutes and is no cause for concern.

# Physical installation



**Warning! Read ‘Safety information’ on page 5 before installing the fixture.**

The fixture is designed for indoor use only and must be used in a dry location with adequate ventilation. Ensure that none of the fixture’s ventilation slots are blocked and ensure that the product is fastened to a secure structure or surface.

Martin™ can supply suitable safety cables and rigging clamps for use with the fixture (see ‘Accessories’ on page 37).

## Fastening the fixture to a flat surface

The fixture can be fastened to a hard, fixed, flat surface that is oriented at any angle. Ensure that the surface can support at least 10 times the weight of all fixtures and equipment to be installed on it.

Fasten the fixture securely. Do not stand it on a surface or leave it where it can be moved or fall over. If you install the fixture in a location where it may cause injury or damage if it falls, secure it as directed below with a securely anchored safety cable that will hold the fixture if the primary fastening method fails.

## Mounting the fixture on a truss

The fixture can be clamped to a truss or similar rigging structure in any orientation. When installing the fixture hanging vertically down, you can use an open-type clamp such as a G-clamp. When installing in any other orientation, you must use a half-coupler clamp (see illustration on right) that completely encircles the truss chord.



To clamp the fixture to a truss:

1. Check that the rigging structure can support at least 10 times the weight of all fixtures and equipment to be installed on it.
2. Block access under the work area.
3. Fold the legs of the mounting bracket together and bolt a rigging clamp securely to the mounting bracket. The bolt used must be M12, grade 8.8 steel minimum. It must pass through both mounting bracket legs and be fastened with a self-locking nut.
4. Working from a stable platform, hang the fixture with its clamp on the truss and fasten the clamp securely.
5. Secure the fixture with a safety cable as directed below.

## **Securing with a safety cable**

Secure the fixture with a safety cable (or other secondary attachment) that is approved for the weight of the fixture so that the safety cable will hold the fixture if a primary attachment fails. Loop the safety cable through the eyebolt in the back of the fixture (see **3** in illustration on page 15) and around a secure anchoring point. Do not loop the safety cable around the fixture's mounting bracket only, as this will leave the fixture unsecured if it separates from the bracket.

## AC power



**Warning!** Read ‘Safety information’ on page 5 before connecting the fixture to AC mains power.



**Warning!** The mains power input cable supplied with the fixture is rated 6 A and can supply only one fixture with mains power. Do not connect any device to the fixture’s **MAINS OUT** power throughput socket when using this input cable. If you want to connect other fixtures to the **MAINS OUT** socket, see ‘Linking fixtures to power in a chain’ on page 14.

For protection from electric shock, the fixture must be grounded (earthed). The power distribution circuit must be equipped with a fuse or circuit breaker and ground-fault (earth-fault) protection.

Socket outlets or external power switches used to supply the fixture with power must be located near the fixture and easily accessible so that the fixture can easily be disconnected from power.

Do not insert or remove live Neutrik PowerCon connectors to apply or cut power, as this may cause arcing at the terminals that will damage the connectors.

Do not use an external dimming system to supply power to the fixture, as this may cause damage to the fixture that is not covered by the product warranty.

The fixture can be hard-wired to a building electrical installation if you want to install it permanently, or a power plug (not supplied) that is suitable for the local power outlets can be installed on the power cable.

If you install a power plug on the power cable, install a grounding type (earthed) plug with integral cable grip that is rated minimum 250 V, 6 A. Follow the plug manufacturer’s instructions and connect the wires in the power cable as shown in this table:

	<b>Live or L</b>	<b>Neutral or N</b>	<b>Earth, Ground or ⊕</b>
<b>US system</b>	Black	White	Green
<b>EU system</b>	Brown	Blue	Yellow/green

The fixture has an auto-ranging power supply that accepts AC mains power at 100V~240V, 50/60Hz. Do not apply AC mains power at any other voltage or frequency to the fixture.

## Linking fixtures to power in a chain

If you obtain a 14 AWG / 1.5 mm<sup>2</sup> power input cable and 14 AWG / 1.5 mm<sup>2</sup> throughput cables from Martin™ (see 'Accessories' on page 37), you can relay mains power from one fixture to another by connecting fixtures to power in a linked daisy-chain, MAINS OUT throughput socket to MAINS IN input socket. Using 14 AWG or 1.5 mm<sup>2</sup> cables from Martin™, you can link:

- Maximum eight (8) RUSH PAR 1 RGBW fixtures in total at 100-120 V, or
- Maximum sixteen (16) RUSH PAR 1 RGBW fixtures in total at 200-240 V.

If you install a power plug on the 14 AWG / 1.5 mm<sup>2</sup> power input cable, install a grounding type (earthed) plug with integral cable grip that is rated minimum 250 V, 16 A.

# Fixture overview

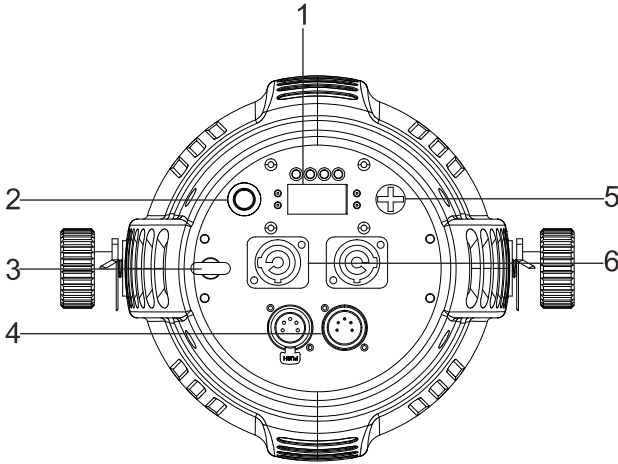

## 1 - Display and control panel

The two LEDs on the control panel indicate the fixture status shown below:

DMX	On	DMX input present
SOUND	Flashing	Sound activation

The four buttons on the control panel have the functions shown below:

MENU	<ul style="list-style-type: none"><li>• Activate menus, or</li><li>• Return to the previous level of the menu structure, or</li><li>• Hold to exit the menus (this occurs automatically after a period where there has been no user input).</li></ul>
DOWN	Go down a menu branch
UP	Go up a menu branch
ENTER	Confirm the selected function

## 2 - Microphone

Built-in microphone for triggering sound-activated scene changes in show mode.

### **3 - Safety cable attachment point**

Eyebolt for securing the fixture with a secondary attachment such as a safety cable.

### **4 - DMX input/output sockets**

A 5-pin male XLR socket accepts input from a DMX512 data link. A 5-pin female XLR output (thru) socket allows the DMX link to be daisy-chained to the next fixture.

### **5 - Fuse**

The fixture's T 6.3 A fuse is located in a fuseholder next to the display.

### **6 - Mains power input and output**

A blue MAINS IN Neutrik PowerCon socket is provided to connect the fixture to AC mains power.

See 'Safety information' on page 5. The light-grey MAINS OUT Neutrik PowerCon socket can be used to supply power to other fixtures only if the supplied power input cable is replaced as directed in this manual and the safety limits given in this manual are respected.



## Control data link

A DMX 512 data link is required in order to control the fixture via DMX or to use the master/slave functionality. The fixture has 5-pin XLR connectors for DMX data input and output.

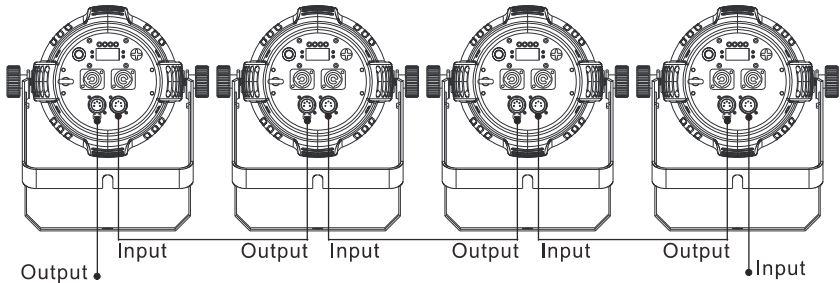

The number of daisy-chained fixtures is limited by the number of DMX channels required by the fixtures in relation to the maximum 512 channels available in one DMX universe. Note that if independent control of a fixture is required, it must have its own DMX channels. Fixtures that are required to behave identically can share the same DMX address and channels. To add more fixtures or groups of fixtures when the above limit is reached, add a DMX universe and another daisy-chained link.

### Tips for reliable data transmission

Use shielded twisted-pair cable designed for RS-485 devices: standard microphone cable cannot transmit control data reliably over long runs. 24 AWG cable is suitable for runs up to 300 meters (1000 ft.). Heavier gauge cable and/or an amplifier are recommended for longer runs. The pin-out on all connectors is:

- pin 1 = shield
- pin 2 = cold (-)
- pin 3 = hot (+)

Pins 4 and 5 in the XLR connectors are not used in the fixture but are available for possible additional data signals as required by the DMX512-A standard. Standard pin-out is:

- pin 4 = data 2 cold (-)
- pin 5 = data 2 hot (+).

To split the link into branches, use a splitter, such as the Martin 4-Channel Opto-Isolated RS-485 Splitter/Amplifier. Terminate the link by installing a termination plug in the output socket of the last fixture. The termination plug, which is a male XLR plug with a 120 Ohm, 0.25 Watt resistor soldered between pins 2 and 3, “soaks up” the control signal so it does not reflect and cause interference. If you use a DMX splitter, terminate each branch of the link.

## Connecting the DMX data link

To connect the fixture to data:

1. Connect the DMX data output from the controller to the closest fixture's male XLR DMX input connector.
2. Connect the DMX output of the fixture closest to the controller to the DMX input of the next fixture and continue connecting fixtures output to input. Terminate the last fixture on the link with a 120-Ohm resistor.

## Fixture setup

This section explains the fixture characteristics that can be set that determine how it can be controlled and will behave. These settings are made using the menus available from the control panel, and are retained, even when the fixture is powered off.

### Using the control menus

A map of the control menu structure can be found in 'Control menus' on page 30.

To access the control menus, press the MENU button. Navigate the menu structure using the MENU, ENTER, DOWN and UP buttons. Select any required menu option using the ENTER button. To return to a higher level in the menu structure without making any change, press the MENU button (this will occur automatically after an interval where there has been no user input.).

### DMX addressing

Addr

The DMX address, also known as the start channel, is the first channel used to receive instructions from a DMX controller. The fixture can be controlled using signals sent by a DMX controller on a number of channels (4, 5 or 7, depending on the DMX mode that has been set). Each DMX-controlled fixture must have a DMX address set. For example, if a fixture has a DMX address of 10 and it is in 5-channel DMX mode, then it uses channels 10, 11, 12, 13 and 14. The next fixture on the DMX link can be set to a DMX address of 15.

For independent control, each fixture must be assigned its own control channels. Two fixtures of the same type may share the same address if identical behavior is desired. Address sharing can be useful for diagnostic purposes and symmetric control.

The DMX address is configured using the `Addr` menu in the control panel.

To set the fixture's DMX address:

1. Select `Addr` and press ENTER.

2. Use the UP and DOWN buttons to select a DMX address.
3. Once the address has been selected, press ENTER to set it (or press MENU to exit without making a change).

## DMX channel modes

CHNd

The fixture provides three control modes enabling varying degrees of DMX control and enabling the efficient use of DMX channel bandwidth. The modes are documented in detail in 'DMX protocols' on page 28 and summarized briefly here:

DMX channel mode	Description
4 channels	Individual control of red, green, blue and white channels for color mixing.
5 channels	Individual control of red, green, blue and white channels for color mixing, plus full range dimming.
7 channels	Individual control of red, green, blue and white channels for color mixing, plus full range dimming. 32 color presets and strobe effects.

To set the fixture's DMX channel mode:

1. Select CHNd and press ENTER.
2. Use the DOWN and UP buttons to select 4Ch, 5Ch or 7Ch DMX channel mode.
3. Once the mode has been selected, press ENTER to set it (or press MENU to exit without making a change).

## Show mode

SHNd

Show mode lets you run a standalone light show without a DMX signal. Music trig, static scene and auto trig options are available. To select a show type:

1. Select SHNd and press ENTER to enter the show mode menu. The fixture will not respond to DMX while you are in this menu.
2. Use the DOWN and UP buttons to select one of the following types:

SH 0

Music trig. Runs random scenes in sync with a music beat if you enable sound activation.

CoLo

Static color display. Shows one of nine preset colors (select CoL1 to CoL9, then select a value) or an RGBW color mix (select Co10, then select colors and values). Sound activation has no effect.

FADE

Auto trig. Runs random scenes that change automatically. You can select from three speeds, fast (SP1) to slow (SP3). Sound activation has no effect.

3. When you have selected a show type, press ENTER to set it (or press MENU to exit without making a change).
4. If you want the fixture to automatically enter show mode when it is not receiving a DMX signal, go into the DMX state menu (see 'DMX state' on page 21) and activate the show mode option.

## Dimmer modes

d1 n d

Four options are available for controlling dimming via DMX:

d1 1

LINEAR – the increase in light intensity appears to be linear as DMX value is increased.

d1 2

SQUARE LAW – light intensity control is finer at low levels and coarser at high levels.

d1 3

INVERSE SQUARE LAW – light intensity control is coarser at low levels and finer at high levels.

d1 4

S-CURVE – light intensity control is finer at low levels and high levels and coarser at medium levels.

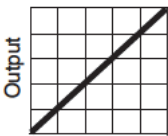

Optically linear

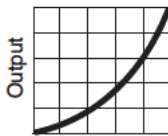

Square law

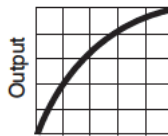

Inverse square law

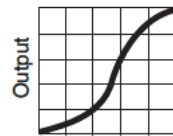

S-curve

To set the fixture's dimmer curve:

1. Select **d1 n d** and press ENTER to confirm. The currently set mode will blink in the display.
2. Use the DOWN and UP buttons to select **d1 1**, **d1 2**, **d1 3** or **d1 4**.

3. Once the mode has been selected, press ENTER to set it (or press MENU to exit without making a change).

## Sound activation (music trig)

Sound

The fixture's built-in microphone can be used to trigger effect and color changes in sync with music if you enable sound activation and run the fixture in show mode.

To enable sound activation:

1. Select **Sound** and press ENTER.
2. Use the DOWN and UP buttons to select **on** (sound activation on) or **off** (sound activation off).
3. Press ENTER to set (or press MENU to exit without making a change).

## Microphone sensitivity

Sens

To adjust the sensitivity of the sound-activation microphone to match the volume of the music:

1. Select **Sens** and press ENTER.
2. Use the DOWN and UP buttons to select a sensitivity level from 0 to 100.
3. Press ENTER to set (or press MENU to exit without making a change).

## DMX state

DMSE

The DMX state menu lets you set the fixture's behavior when it is powered on but is not receiving a DMX signal. You can set the fixture to:

- enter show mode and run the standalone show type selected in the show mode menu (see 'Show mode' on page 19),
- blackout, or
- return to its last state.

When a fixture has entered one of these DMX states, it is called out of its state and responds to DMX as soon as it receives a DMX signal.

To select a DMX state option:

1. Select **BASE** and press ENTER.
2. Use the DOWN and UP buttons to select **BASE** (fixture enters show mode), **BLACK** (fixture blacks out) or **LAST** (fixture returns to the last state it was in before it received a DMX signal).
3. Press ENTER to set (or press MENU to exit without making a change).

## LED display on/off

**LED**

To set the control panel's LED display to be on all the time, or to automatically sleep when not in use:

1. Select **LED** menu and press ENTER.
2. Use the DOWN and UP buttons to select ON (LED on) or OFF (LED off when not in use). Press ENTER to set (or press MENU to exit without making a change).

## LED display inversion

**DISP**

To invert the control panel's LED display so that it is easier to read depending on which way up the fixture is installed:

1. Select **DISP** menu and press ENTER.
2. Use the DOWN and UP buttons to select **DISP** (normal display orientation) or **DISP** (invert display). Press ENTER to set it (or press MENU to exit without making a change).

## White balance adjustment

**BALR**

To adjust the white balance mix:

1. Select **BALR** and press ENTER.
2. Use the DOWN and UP buttons to select **RED**, **GREEN** or **BLUE**.
3. Press ENTER to setup.

4. Use the DOWN and UP buttons to change the value (125~255).
5. Once the correct value has been selected, press ENTER to set it (or press MENU to exit without making a change).

## Manual mode

MANU

The Manual menu can be used to control effects using the fixture's control panel. This lets you test effects and display a single scene without a DMX signal.

To manually control effects:

1. Select **MANU** and press ENTER.
2. Use the DOWN and UP buttons to select **red** (red), **GrEE** (green), **blUE** (blue), **WHITe** (white), **diMm** (dimmer) or **Stro** (strobe). Press ENTER to select (or press MENU to exit without making a change).
3. Use the DOWN and UP buttons to specify a value from 0 to 255 for the selected effect.
4. Press ENTER to confirm the value and activate the effect (or press MENU to exit without making a change).
5. Each time you confirm a selection with ENTER, press MENU to go back through the menu structure.

Note that the fixture will not respond to DMX commands while you are controlling effects in the Manual menu. To restore DMX control, exit the Manual menu.

If you power the fixture off while you are controlling effects in the Manual menu, the effects are not restored and the fixture does not return to the Manual menu when you power it on again.

## Auto test

TEST

To perform a complete test of all of the fixture functions:

1. Select **TEST** and press ENTER. The fixture will run a self-test routine.
2. Press MENU to exit.

## Temperature readout

TEMP

To display the fixture's onboard temperature:

1. Select **TEMP** and press ENTER. The display will show the temperature of the unit.
2. Press MENU to exit.

## Fixture operating hours readout

FHRS

To display the fixture's total operating hours counter:

1. Select **FHRS** and press ENTER. The display will show the number of hours the unit has been run.
2. Press MENU to exit.

## Firmware version

VER

To display the fixture's installed firmware version number:

1. Select **VER** and press ENTER. The display will show the version of software installed on the fixture.
2. Press MENU to exit.



## **Effects**

See DMX protocols on page 28 for a full list of the DMX channels and values required to control the different effects.

### **Color control**

All DMX modes offer full RGBW color mixing.

32 color presets are available in 7-channel mode.

### **Electronic dimming**

Overall intensity can be adjusted 0-100% using electronic dimming in 5 and 7-channel DMX modes.

### **Shutter/Strobe**

The shutter/strobe effect provides instant open and blackout, variable speed regular and random strobe.

The shutter/strobe effect is available in 7-channel DMX mode.

# Maintenance



**Warning! Read ‘Safety information’ on page 5 before servicing the fixture.**

Refer any service operation not described in this user manual to a qualified service technician.

Disconnect mains power before cleaning or servicing the fixture.

Service fixtures in an area where there is no risk of injury from failing parts, tools or other materials.

The user may carry out the service operations described in this manual. All other service operations must be carried out by an authorized Martin™ service technician. Do not try to repair the fixture yourself, as you may create a safety risk or cause damage that is not covered by the product warranty.

Installation, on-site service and maintenance can be provided worldwide by the Martin Professional™ Global Service organization and its approved agents, giving owners access to Martin’s expertise and product knowledge in a partnership that will ensure the highest level of performance throughout the product’s lifetime. Please contact Martin™ for details.

## Cleaning

Excessive dust, smoke fluid, and particle buildup degrades performance, causes overheating and will damage the fixture. Damage caused by inadequate cleaning or maintenance is not covered by the product warranty.

The cleaning of external optical lenses must be carried out periodically to optimize light output. Cleaning schedules for lighting fixtures vary greatly depending on the operating environment. It is therefore impossible to specify precise cleaning intervals for the fixture. Environmental factors that may result in a need for frequent cleaning include:

- Use of smoke or fog machines.
- High airflow rates (near air conditioning vents, for example).
- Presence of cigarette smoke.
- Airborne dust (from stage effects, building structures and fittings or the natural environment at outdoor events, for example).

If one or more of these factors is present, inspect fixtures within their first 100 hours of operation to see whether cleaning is necessary. Check again at frequent intervals. This procedure will allow you to assess cleaning requirements in your particular situation. If in doubt, consult your RUSH by Martin dealer about a suitable maintenance schedule.

Use gentle pressure only when cleaning, and work in a clean, well-lit area. Do not use any product that contains solvents or abrasives, as these can cause surface damage.

To clean the fixture:

1. Disconnect the fixture from power and allow it to cool for at least 10 minutes.
2. Vacuum or gently blow away dust and loose particles from the outside of the fixture with low-pressure compressed air.
3. Clean the surfaces by wiping gently with a soft, clean lint-free cloth moistened with a weak detergent solution. Do not rub glass surfaces hard: lift particles off with a soft repeated press. Dry with a soft, clean, lint-free cloth or low-pressure compressed air. Remove stuck particles with an unscented tissue or cotton swab moistened with glass cleaner or distilled water.
4. Check that the fixture is dry before reapplying power.

## **Replacing the primary fuse**

If the fixture is completely dead, the fixture's primary fuse F1 may have blown and it may be necessary to install a new fuse. This fuse is located in a fuseholder next to the MAINS OUT socket on the connections panel. See 'Fixture overview' on page 15.

If you need to replace a fuse:

1. Disconnect the fixture from power and allow it to cool for at least 10 minutes.
2. Unscrew the cap of the fuseholder and remove the fuse. Replace with a fuse of the same size and rating only.
3. Reinstall the fuseholder cap before reapplying power.

## **Service and repairs**

There are no user serviceable parts inside the fixture. Do not open the housing.

Do not try to repair the fixture by yourself as this may result in damage, malfunction and it may potentially void your product warranty. The equipment must only be serviced or repaired by an authorized RUSH by Martin service technician.

Installation, on-site service and maintenance can be provided worldwide by the Martin Professional Global Service organization and its approved agents, giving owners access to Martin's expertise and product knowledge in a partnership that will ensure the highest level of performance throughout the product's lifetime. Please contact your RUSH by Martin supplier for details.

# DMX protocols

## 4-channel mode

Channel	Value	Function
1	0-255	Red 0-100%
2	0-255	Green 0-100%
3	0-255	Blue 0-100%
4	0-255	White 0-100%

## 5-channel mode

Channel	Value	Function
1	0-255	Red 0-100%
2	0-255	Green 0-100%
3	0-255	Blue 0-100%
4	0-255	White 0-100%
5	0-255	Dimmer 0-100%

## 7-channel mode

Channel	Value	Function
1	0-255	Red 0-100%
2	0-255	Green 0-100%
3	0-255	Blue 0-100%
4	0-255	White 0-100%
5		<b>Color presets</b>
	0-7	Off
	8-15	Color 1
	16-23	Color 2
	24-30	Color 3
	31-38	Color 4
	39-46	Color 5
	47-54	Color 6
	55-61	Color 7
	62-69	Color 8
	70-77	Color 9
	78-85	Color 10
	86-92	Color 11
	93-100	Color 12
	101-108	Color 13
	109-116	Color 14
	117-123	Color 15
	124-131	Color 16
	132-139	Color 17

Channel	Value	Function
	140-147	Color 18
	148-154	Color 19
	155-162	Color 20
	163-170	Color 21
	171-178	Color 22
	179-185	Color 23
	186-193	Color 24
	194-201	Color 25
	202-209	Color 26
	210-216	Color 27
	217-224	Color 28
	225-232	Color 29
	233-240	Color 30
	241-247	Color 31
	248-255	Color 32
6	0-255	Dimmer 0-100%
7		<b>Strobe</b>
	0-7	Off
	8-15	Open
	16-131	Strobe - slow-fast
	132-139	Open
	140-181	Pulse - fast close & slow open
	182-189	Open
	190-231	Pulse - slow close & fast open
	232-239	Open
	240-247	Random strobe
	248-255	Open

# Control menus

For more information on using the menus in the control panel, see 'Using the control menus' on page 18.

Menu	Option/setting	Explanation
Addr	1 512	Fixture DMX address setting
Chnd	4Ch	4-channel DMX mode
	5Ch	5-channel DMX mode
	7Ch	7-channel DMX mode
Shnd	Sh 0	Show mode – music trig (enable sound activation to run show)
	Col0	Show mode – static color (sound activation not used)
	Col1	Red (set intensity value)
	Col2	Blue (set intensity value)
	Col3	Purple (set intensity value)
	Col4	Orange (set intensity value)
	Col5	Green (set intensity value)
	Col6	Yellow (set intensity value)
	Col7	Magenta (set intensity value)
	Col8	Light blue (set intensity value)
	Col9	White (set intensity value)
	Col10	RGBW color mixing (select color, then set intensity value)
	FADE	Show mode – auto trig (sound activation not used)
	SP 1	Rapid scene changes
SP 2	Medium scene changes	
SP 3	Slow scene changes	

Menu	Option/setting	Explanation
dimd	di 1	Dimmer mode 1 - Linear
	di 2	Dimmer mode 2 – Square law
	di 3	Dimmer mode 3 – Inverse square law
	di 4	Dimmer mode 4 – S-curve
Sound	on	Sound activation, must be enabled to run music trig action in show mode
	off	No sound activation
Sens	1 100	Microphone sensitivity for sound activation
dntst	nrst	DMX state: fixture enters show mode if DMX signal stops
	blnd	DMX state: fixture blacks out if DMX signal stops
	lrst	DMX state: fixture returns to its last state if DMX signal stops
LED	on	LED display off when not in use.
	off	LED display on all the time.
disP	disP	Normal display
	dsIP	Invert display
BALA	red 125	White balance - red
	grEE ~	White balance – green
	blue 255	White balance – blue
MANU	red	Manual mode - red
	grEE	Manual mode – green
	blue 0	Manual mode – blue
	WHTE ~	Manual mode – white
	dim	Manual mode – dimmer
	stro	Manual mode - strobe

Menu	Option/setting	Explanation
TEST		Automatic test
TEMP		Temperature readout
Fhrs		Total fixture operating hours counter
ver		Currently installed firmware version



# Troubleshooting

This section describes possible problems and provides some suggestions for easy troubleshooting:

Symptom	Potential cause	Remedies
No light from fixture, or fans not working.	If no DMX signal is present, fixture may be set to 'Blackout' DMX state.  Power supply issue, such as blown fuse, faulty connector or damaged cable.	Change setting in DMX state menu.  Check whether fixture's power indicator LED is lit. Check all power connections and cables. Replace fixture fuse.
Fixture does not react to music beat.	Fixture not in show mode. Sound activation disabled. Sound activation microphone sensitivity too low for music source. Fixture receiving DMX.	Set fixture to show mode in DMX state menu. Enable.  Adjust microphone sensitivity.  Tap microphone to check correct functionality. The fixture should react when in sound activation mode. Stop DMX signal.

Symptom	Potential cause	Remedies
<p>Fixture does not respond to DMX control.</p>	<p>Incorrect DMX addressing.</p> <p>Fault on DMX link due to damaged connector or cable, or interference from proximity to a high-voltage installation.</p>	<p>Ensure that fixture's DMX address matches address set on DMX control device.</p> <p>Check that fixture's DMX LED is on, and if not, check all cables and connections on the DMX link.</p> <p>Check that DMX link is terminated.</p> <p>Check that all devices on the DMX link use standard DMX polarity.</p> <p>Try to control the fixture with another DMX control device.</p> <p>Move or shield link if it is close to an unshielded high-voltage installation.</p>

# Specifications

## Physical

Weight ..... 3.6 kg (10.0 lbs.)  
Dimensions ..... 260 x 195 x 293 mm (11.4 x 7.7 x 11.5 in.)

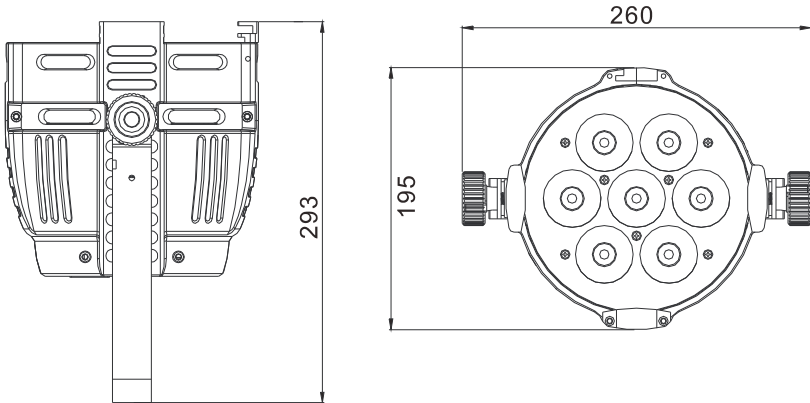

## Dynamic Effects

Color mixing ..... RGBW  
Color selection ..... 32 color presets  
Electronic dimming ..... 0-100%  
Strobe and pulse effects ..... Variable speed and action, random strobe  
Electronic shutter effect ..... Instant open and blackout

## Control and Programming

Control options ..... DMX, standalone  
DMX channels ..... 4/5/7  
Stand-alone trigger options ..... Music trig, auto trig  
Standalone built-in shows ..... Random, preset colors, or variable fade  
Settings, addressing and programming ..... Control panel with LCD display  
Sound activation ..... Adjustable microphone sensitivity  
White balance control ..... RGB adjustment  
DMX compliance ..... USITT DMX512/1990

## Optics and Photometric Data

Light source ..... 7 x 10 W RGBW CREE MC-E LEDs  
Beam angle ..... 20°  
Minimum LED lifetime\* ..... 50 000 hours (to >70% luminous output)  
*\*Manufacturer's figure obtained under manufacturer's test conditions*

## Construction

Color ..... Black  
Protection rating ..... IP20

## Installation

Mounting ..... Adjustable folding bracket, surface or truss mount  
Orientation ..... Any  
Location ..... For indoor use only

## Connections

AC power in/thru ..... Neutrik PowerCon  
DMX data in/thru ..... 5-pin locking XLR

## Electrical

AC power ..... 100-240 V, 50/60 Hz  
Power consumption ..... 78 W  
Fuse ..... T 6.3 A

## Typical power and current

110 V, 60 Hz ..... 78 W, 1.1 A  
230 V, 50 Hz ..... 78 W, 0.62 A

*Measurements made at nominal voltage with all LEDs at full intensity. Allow for a deviation of +/- 10%.*

## Thermal

Maximum ambient temperature ( $T_a$  max.) ..... 40° C (104° F)  
Minimum ambient temperature ( $T_a$  min) ..... 0° C (32° F)  
Total heat dissipation\* ..... 270 BTU/hr.

*\*Calculated, +/- 10%, at full intensity, full white*

## Approvals



EU safety ..... EN 60598-2-17 (EN 60598-1), EN 62471, EN 62493  
EU EMC ..... EN 55015, EN 55103-1, EN 55103-2,  
..... EN 61000-3-2, EN 61000-3-3, EN 61547

US safety ..... UL 1573  
US EMC ..... FCC Part 15 Class A  
Canadian safety ..... CSA C22.2 No. 166  
Canadian EMC ..... ICES-003 Class A  
Australia/NZ ..... C-TICK N4241

## Included items

Power cable, 1.5 m, without mains plug

## Accessories

### *Cables, 16 A, for connection to power in chains*

- Power input cable, 14 AWG, SJT, 1.5 mm<sup>2</sup>, H05VV-F,  
with PowerCon input connector, 3 m (9.8 ft.) ..... P/N 11541508
- Power relay cable, 14 AWG, SJT, 1.5 mm<sup>2</sup>, H05VV-F,  
with PowerCon connectors, 1.4 m (4.6 ft.) ..... P/N 11541509
- Power relay cable, 14 AWG, SJT, 1.5 mm<sup>2</sup>, H05VV-F,  
with PowerCon connectors, 2.25 m (7.4 ft.) ..... P/N 11541510
- Power relay cable, 14 AWG, SJT, 1.5 mm<sup>2</sup>, H05VV-F,  
with PowerCon connectors, 3.25 m (10.7 ft.) ..... P/N 11541511

### *Power connectors*

- Neutrik PowerCon NAC3FCA  
power input connector, cable mount, blue ..... P/N 05342804
- Neutrik PowerCon NAC3FCB  
power output connector, cable mount, light grey ..... P/N 05342805

## Related Items

- RUSH Software Uploader 1™ ..... P/N 91611399

## Ordering Information

- RUSH PAR 1 RGBW™ EU model, in cardboard box ..... P/N 90480000
- RUSH PAR 1 RGBW™ US model, in cardboard box ..... P/N 90480005

*Specifications are subject to change without notice. For latest product specifications, see [www.martin.com](http://www.martin.com)*

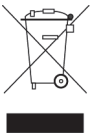

### **Disposing of this product**

RUSH by Martin™ products are supplied in compliance with Directive 2012/19/EC of the European Parliament and of the Council of the European Union on WEEE (Waste Electrical and Electronic Equipment), where applicable. Help preserve the environment! Ensure that this product is recycled at the end of its life. Your supplier can give details of local arrangements for the disposal of RUSH by Martin products.





**RUSH**<sup>TM</sup>  
by Martin